

Cam Units CHR
Schieber CHR
Unità a Camme CHR

OMCR[®]
STANDARD DIE COMPONENTS

OMCR CODE	Work Angle	Slider Width (mm)	Closed Cam Height (mm)	Work Area W x H (mm)	Max Work Force with shoulder 10 ⁶ cycles (kN)	Extraction Force (kN)			Page number
	β					E _F			
						F _s	Spring	Gas Spring	
CHR070	0°÷60° (5° steps)	70	225	70x75	90	0,25÷0,38	1,30÷1,74	834	
CHR080	0°÷60° (5° steps)	80	275	80x75	153	0,56÷0,87	1,48÷2,08	838	
CHR165	0°÷60° (5° steps)	165	300	165x120	340	1,16÷1,49	1,91÷2,46	842	
CHR200	0°÷60° (5° steps)	200	300	200x120	408	1,82÷2,35	3,75÷4,82	846	
CHR300	0°÷60° (5° steps)	300	375	300x160	521	3,89÷5,09	6,85÷9,40	850	
CHR400	0°÷60° (5° steps)	400	375	400x160	521	3,89÷5,09	6,85÷9,40	854	

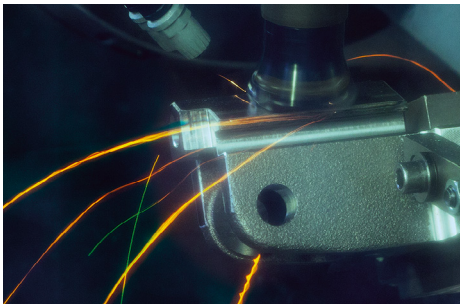

Advanced machines and production systems

AERIAL CAM UNIT - OBEN HÄNGENDER SCHIEBER - UNITÀ A CAMME SOSPESA

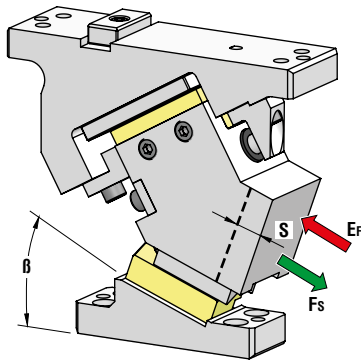

OMCR CODE	Work Angle	Stroke (mm)	Max Work Force with shoulder (kN)	Extraction Force (kN)	
	β	S	F _s	Spring	Gas Spring
CHR070.00	0°	19,28	90	0,38	1,74
CHR070.05	5°	21,29	90	0,38	1,74
CHR070.10	10°	23,34	90	0,38	1,74
CHR070.15	15°	25,44	90	0,38	1,74
CHR070.20	20°	27,65	90	0,38	1,74
CHR070.25	25°	30	90	0,38	1,74
CHR070.30	30°	32,55	90	0,38	1,74
CHR070.35	35°	35,38	90	0,38	1,74
CHR070.40	40°	38,57	90	0,38	1,74
CHR070.45	45°	42,26	90	0,38	1,74
CHR070.50	50°	46,67	90	0,38	1,74
CHR070.55	55°	43,59	90	0,28	1,49
CHR070.60	60°	50	90	0,25	1,30

*Return Type: G = Gas Spring / S = Spring

		Art.	Work Angle = 5°	Return Type*
		CHR070	05	G

OMCR CODE	Work Angle	Overall Dimensions (mm)				
	β	A	B	C	D	E
CHR070.00	0°	237,37	85	102	252	81,37
CHR070.05	5°	234,87	86,28	92	242	81,53
CHR070.10	10°	232,82	88,76	81	231	80,24
CHR070.15	15°	217,54	96,59	57	207	66,67
CHR070.20	20°	224,52	99,67	52	202	75,62
CHR070.25	25°	223,46	105,45	42	192	75,76
CHR070.30	30°	211,54	112,99	30	180	66,03
CHR070.35	35°	210,68	117,20	17	167	66,86
CHR070.40	40°	204,84	125,07	4	154	63,69
CHR070.45	45°	198,15	131,28	-2	148	58,40
CHR070.50	50°	190,95	135,15	-21	129	49,59
CHR070.55	55°	190,51	146	-23	127	56,02
CHR070.60	60°	185,81	155,86	-35	115	56,99

AERIAL CAM UNIT - OBEN HÄNGENDER SCHIEBER - UNITÀ A CAMME SOSPESA

X VIEW

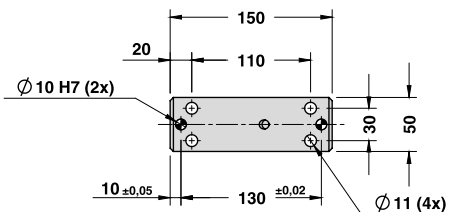
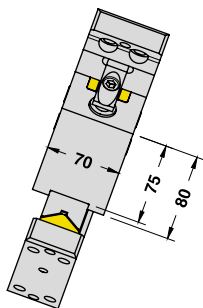

CAM DIAGRAM

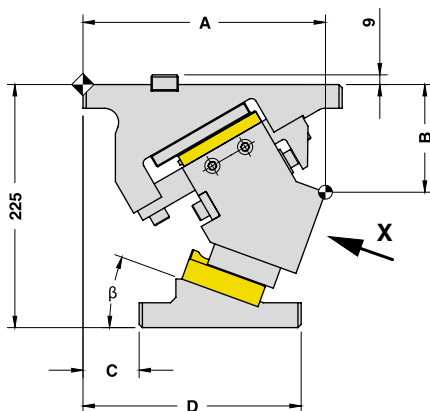
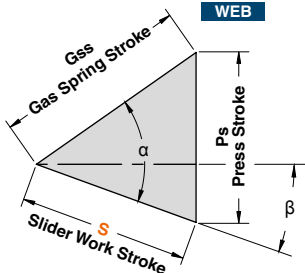

Work Angle	Inner Angle	Slider Work Stroke (mm)	Press Stroke (mm)	Gas Spring Stroke (mm)
β	α	S	Ps	Gss
0°	50°	19,28	22,98	30
5°	50°	21,29	23,07	30
10°	50°	23,34	23,34	30
15°	50°	25,44	23,79	30
20°	50°	27,65	24,46	30
25°	50°	30,00	25,36	30
30°	50°	32,55	26,54	30
35°	50°	35,38	28,06	30
40°	50°	38,57	30,00	30
45°	50°	42,26	32,50	30
50°	50°	46,67	35,75	30
55°	55°	43,59	35,70	25
60°	60°	50,00	43,30	25

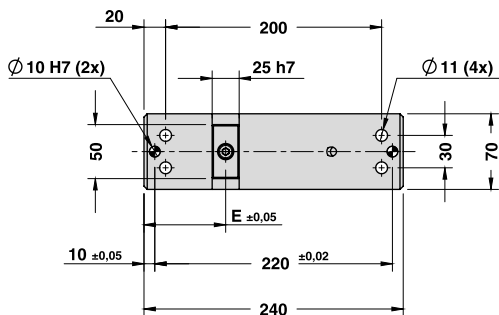

Cam Units CHR

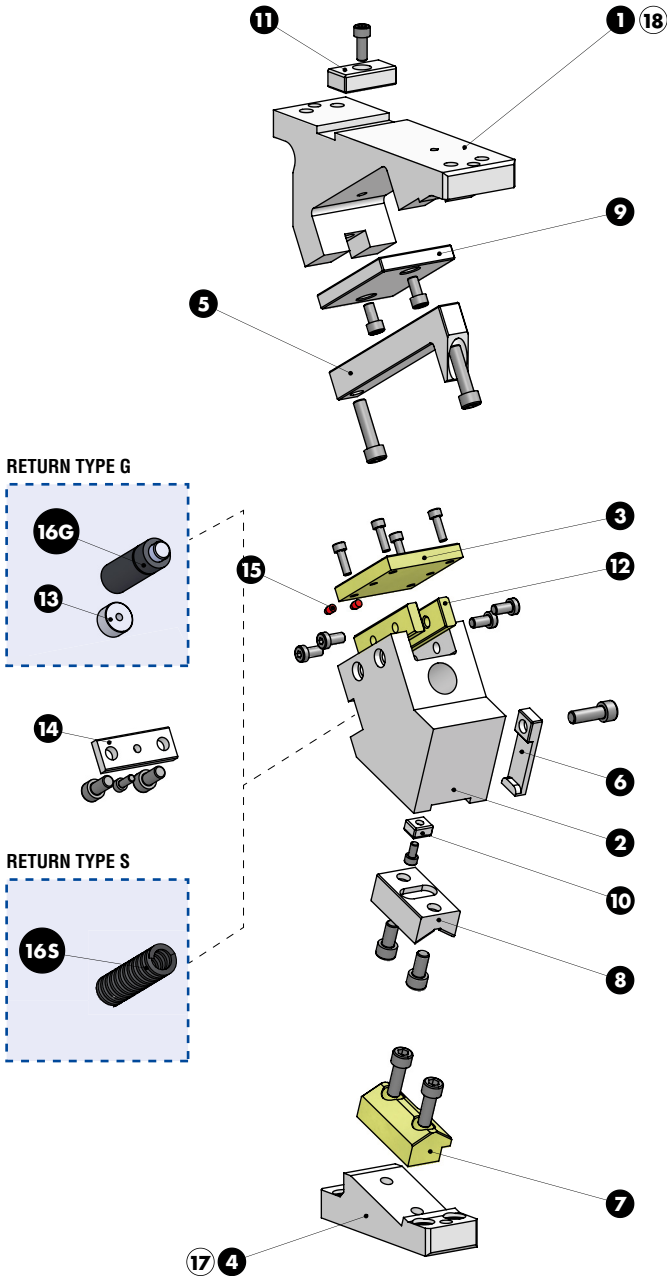

AERIAL CAM UNIT - OBEN HÄNGENDER SCHIEBER - UNITÀ A CAMME SOSPESA

SLIDER STRUCTURE, POSITIVE RETURN STRUCTURE AND CLEARANCES

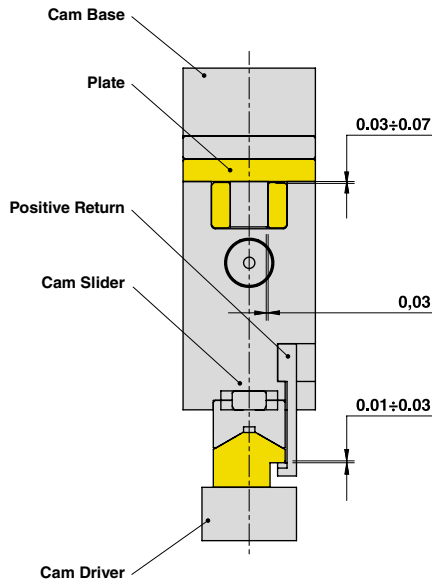

Cam Units CHR

PART LIST

Particular number	Description	Material	Quantity
1	Cam Base	GGG-50	1
2	Cam Slider	GGG-50	1
3	Plate	CuZn25Al5 + Graphite - HB > 190	1
4	Cam Driver	GG-25	1
5	Guide Bar	CK45	1
6	Positive Return	CK45	1
7	Male "V" Driver	CuZn25Al5 + Graphite - HB > 190	1
8	Female "V" Driver	CK45	1
9	Wear Plate	CK45	1
10	Key	CK45	1
11	Key	CK45	1
12	Wear Plate	CuZn25Al5 + Graphite - HB > 190	2
13	Spring Spacer	CK45	1
14	Spring Stopper Plate	CK45	1
15	Elastomer Cap	Elastomer 92SH	2
16G	Gas Spring - Return Type G	-	1
16S	Spring - Return Type S	-	1
17	Cam Driver Fixing Screws M12x50 DIN 912	-	4
18	Cam Base Fixing Screws M12x50 DIN 912	-	4

AERIAL CAM UNIT - OBEN HÄNGENDER SCHIEBER - UNITÀ A CAMME SOSPESA

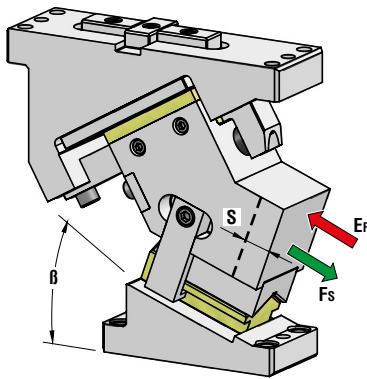

OMCR CODE	Work Angle	Stroke (mm)	Max Work Force with shoulder (kN)	Extraction Force (kN)	
				Spring	Gas Spring
CHR080.00	0°	32,14	153	0,87	2,08
CHR080.05	5°	35,49	153	0,87	2,08
CHR080.10	10°	38,89	153	0,87	2,08
CHR080.15	15°	42,40	153	0,87	2,08
CHR080.20	20°	46,08	153	0,87	2,08
CHR080.25	25°	50	153	0,87	2,08
CHR080.30	30°	54,25	153	0,87	2,08
CHR080.35	35°	58,96	153	0,87	2,08
CHR080.40	40°	64,28	153	0,87	2,08
CHR080.45	45°	70,44	153	0,87	2,08
CHR080.50	50°	77,79	153	0,87	2,08
CHR080.55	55°	78,46	153	0,71	1,77
CHR080.60	60°	80	153	0,56	1,48

*Return Type: G = Gas Spring / S = Spring



Art.	Work Angle = 5°	Return Type*
CHR080	05	G

OMCR CODE	Work Angle	Overall Dimensions (mm)				
		β	A	B	C	D
CHR080.00	0°	280	110	135	305	99,50
CHR080.05	5°	281,31	115,93	125	295	116,50
CHR080.10	10°	277,50	117,84	110	280	115,87
CHR080.15	15°	280,48	120,72	105	275	123,20
CHR080.20	20°	276,16	124,55	95	265	121,57
CHR080.25	25°	271,47	129,29	80	250	121,07
CHR080.30	30°	264,33	134,92	65	235	116,77
CHR080.35	35°	260,66	141,38	55	225	116,26
CHR080.40	40°	252,32	147,76	35	205	110,84
CHR080.45	45°	247,46	156,61	30	200	109,54
CHR080.50	50°	237,80	165,27	15	185	103,62
CHR080.55	55°	231,36	174,53	0	170	117,12
CHR080.60	60°	233,95	185,89	0	170	116,03

AERIAL CAM UNIT - OBEN HÄNGENDER SCHIEBER - UNITÀ A CAMME SOSPESA

X VIEW

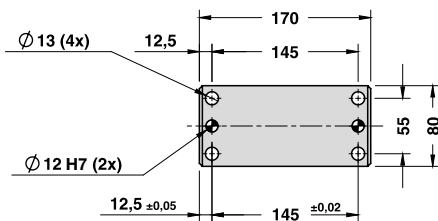
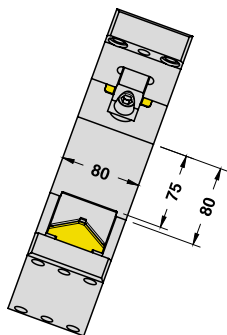

CAM DIAGRAM

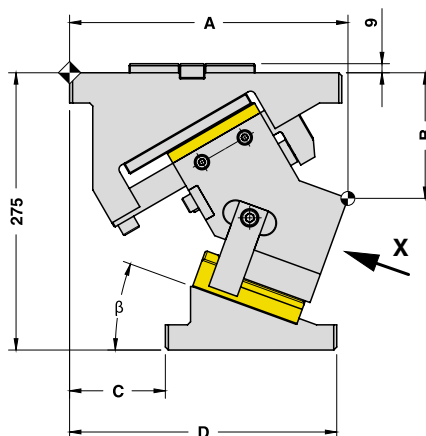
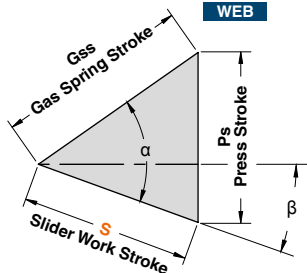

Work Angle	Inner Angle	Slider Work Stroke (mm)	Press Stroke (mm)	Gas Spring Stroke (mm)
β	α	S	Ps	Gss
0°	50°	32,14	38,30	50
5°	50°	35,49	38,45	50
10°	50°	38,89	38,89	50
15°	50°	42,40	39,65	50
20°	50°	46,08	40,76	50
25°	50°	50,00	42,26	50
30°	50°	54,25	44,23	50
35°	50°	58,96	46,76	50
40°	50°	64,28	50,00	50
45°	50°	70,44	54,17	50
50°	50°	77,79	59,59	50
55°	55°	78,46	64,27	45
60°	60°	80,00	69,28	40

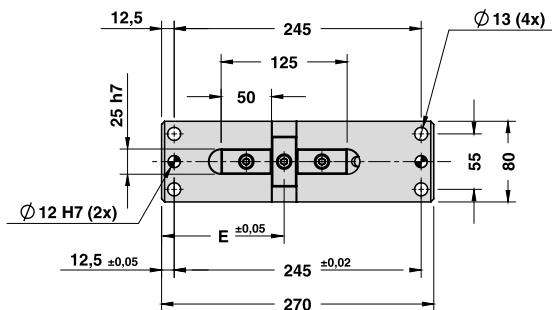

Cam Units CHR

AERIAL CAM UNIT - OBEN HÄNGENDER SCHIEBER - UNITÀ A CAMME SOSPESA

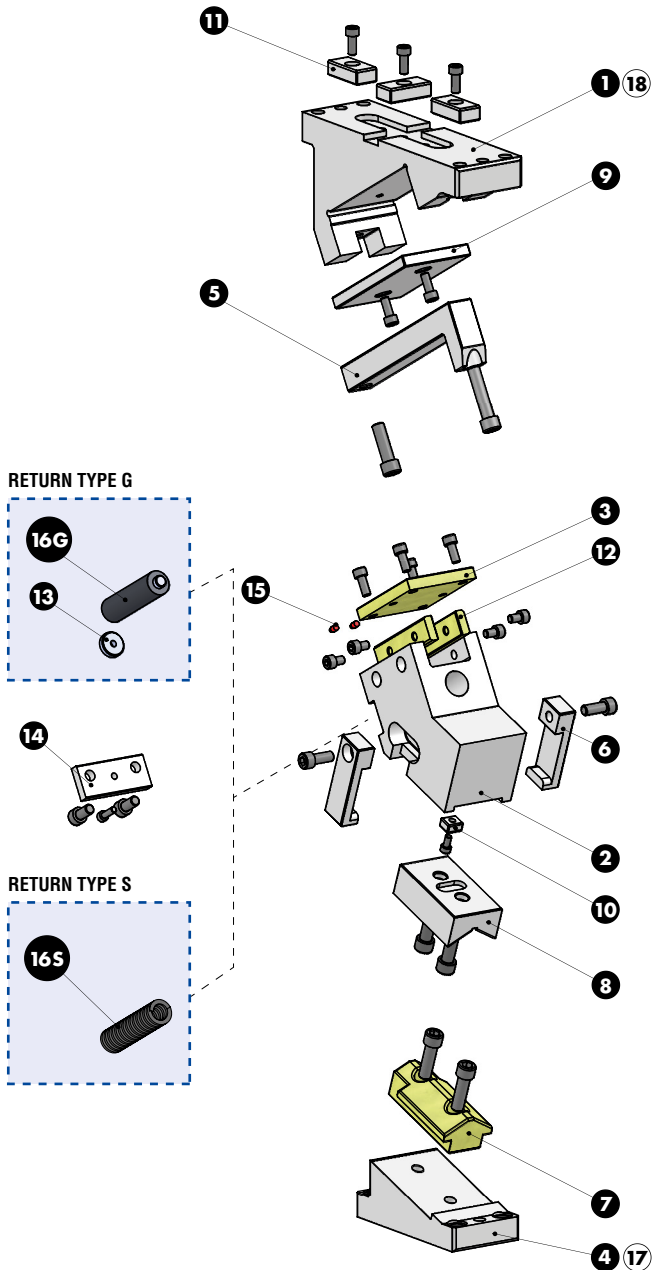

AERIAL CAM UNIT - OBEN HÄNGENDER SCHIEBER - UNITÀ A CAMME SOSPESA

SLIDER STRUCTURE, POSITIVE RETURN STRUCTURE AND CLEARANCES

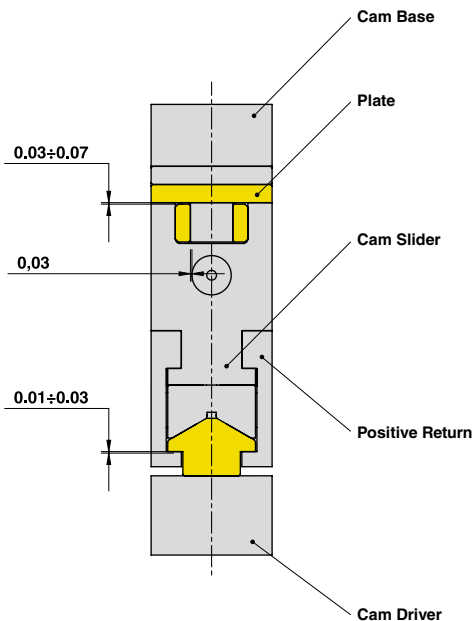

PART LIST

Particular number	Description	Material	Quantity
1	Cam Base	GGG-40	1
2	Cam Slider	GG-25	1
3	Plate	CuZn25Al5 + Graphite - HB > 190	1
4	Cam Driver	GG-25	1
5	Guide Bar	CK45	1
6	Positive Return	CK45	2
7	Male "V" Driver	CuZn25Al5 + Graphite - HB > 190	1
8	Female "V" Driver	CK45	1
9	Wear Plate	CK45	1
10	Key	CK45	1
11	Key	CK45	3
12	Wear Plate	CuZn25Al5 + Graphite - HB > 190	2
13	Spring Spacer	CK45	1
14	Spring Stopper Plate	CK45	1
15	Elastomer Cap	Elastomer 92SH	2
16G	Gas Spring - Return Type G	-	1
16S	Spring - Return Type S	-	1
17	Cam Driver Fixing Screws M12x50 DIN 912	-	4
18	Cam Base Fixing Screws M12x50 DIN 912	-	4

AERIAL CAM UNIT - OBEN HÄNGENDER SCHIEBER - UNITÀ A CAMME SOSPESA

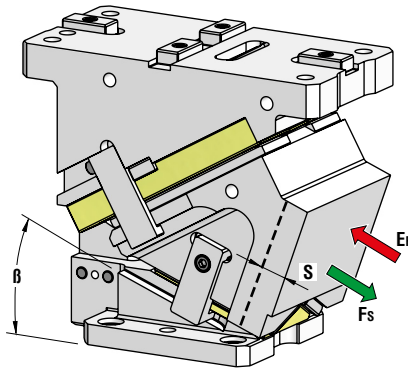

OMCR CODE	Work Angle	Stroke (mm)	Max Work Force with shoulder (kN)	Extraction Force (kN)	
	β			S	F _s
CHR165.00	0°	32,14	340	1,49	2,46
CHR165.05	5°	35,49	340	1,49	2,46
CHR165.10	10°	38,89	340	1,49	2,46
CHR165.15	15°	42,40	340	1,49	2,46
CHR165.20	20°	46,08	340	1,49	2,46
CHR165.25	25°	50	340	1,49	2,46
CHR165.30	30°	54,25	340	1,49	2,46
CHR165.35	35°	58,96	340	1,49	2,46
CHR165.40	40°	64,28	340	1,49	2,46
CHR165.45	45°	70,44	340	1,49	2,46
CHR165.50	50°	77,79	340	1,49	2,46
CHR165.55	55°	87,17	340	1,33	2,20
CHR165.60	60°	100	340	1,16	1,91

OPTION CODE

N

Dowel pin hole Ø16 H7 drilled on Cam Base

*Return Type: G = Gas Spring / S = Spring



Art.	Work Angle = 5°	Return Type*	OPTION CODE
CHR165	05	G	N N16

OMCR CODE	Work Angle	Overall Dimensions (mm)						
	β	A	B	C	D	E	F	G
CHR165.00	0°	335,84	96,98	128	318	154,84	55	120
CHR165.05	5°	335,25	100,91	113	303	155,32	55	120
CHR165.10	10°	337,27	111,09	101	291	159,30	50	120
CHR165.15	15°	329,78	122,46	80	270	156,45	45	120
CHR165.20	20°	332,68	129,99	70	260	162,11	42	120
CHR165.25	25°	332,88	138,62	58	248	167,33	37	120
CHR165.30	30°	334,28	148,28	48	238	170,39	30	120
CHR165.35	35°	329,80	158,89	33	223	167,66	25	120
CHR165.40	40°	321,35	170,38	15	205	161,18	25	120
CHR165.45	45°	314,86	182,66	0	190	155,49	25	120
CHR165.50	50°	307,27	195,63	-15	175	149,10	0	120
CHR165.55	55°	296,59	210,30	-32	158	121,17	0	125
CHR165.60	60°	288,56	222,26	-45	145	113,04	0	125

AERIAL CAM UNIT - OBEN HÄNGENDER SCHIEBER - UNITÀ A CAMME SOSPESA

X VIEW

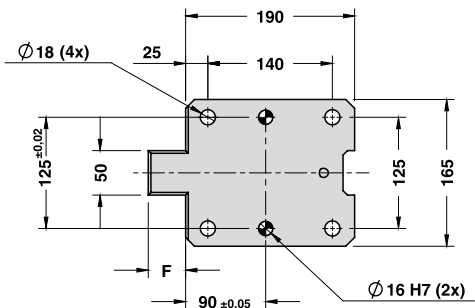
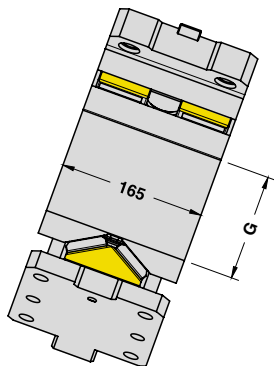

CAM DIAGRAM

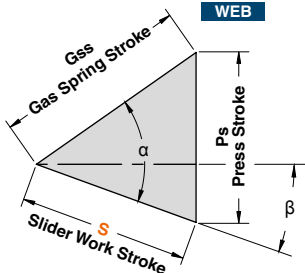

Accelerator available for work angles from 0° to 25°

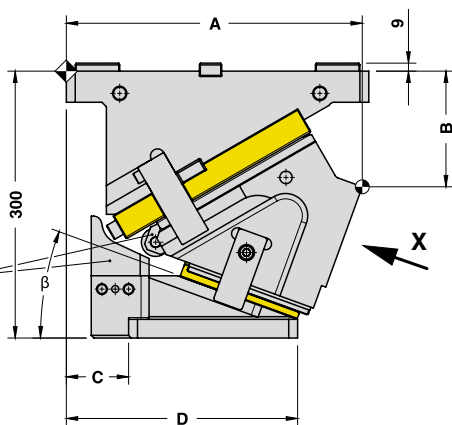

Cam Units CHR

Work Angle	Inner Angle	Slider Work Stroke (mm)	Press Stroke (mm)	Gas Spring Stroke (mm)
β	α	S	Ps	Gss
0°	50°	32,14	38,30	50
5°	50°	35,49	38,45	50
10°	50°	38,89	38,89	50
15°	50°	42,40	39,65	50
20°	50°	46,08	40,76	50
25°	50°	50,00	42,26	50
30°	50°	54,25	44,23	50
35°	50°	58,96	46,76	50
40°	50°	64,28	50,00	50
45°	50°	70,44	54,17	50
50°	50°	77,79	59,59	50
55°	55°	87,17	71,41	50
60°	60°	100,00	86,60	50

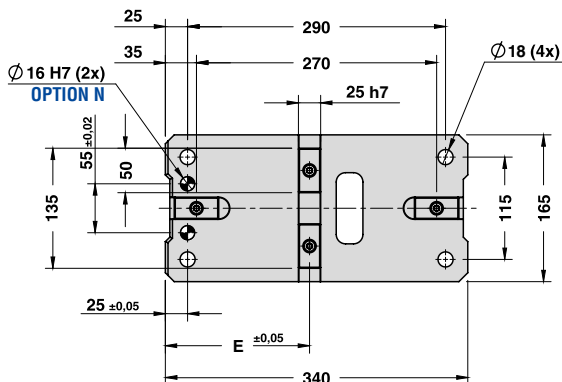

AERIAL CAM UNIT - OBEN HÄNGENDER SCHIEBER - UNITÀ A CAMME SOSPESA

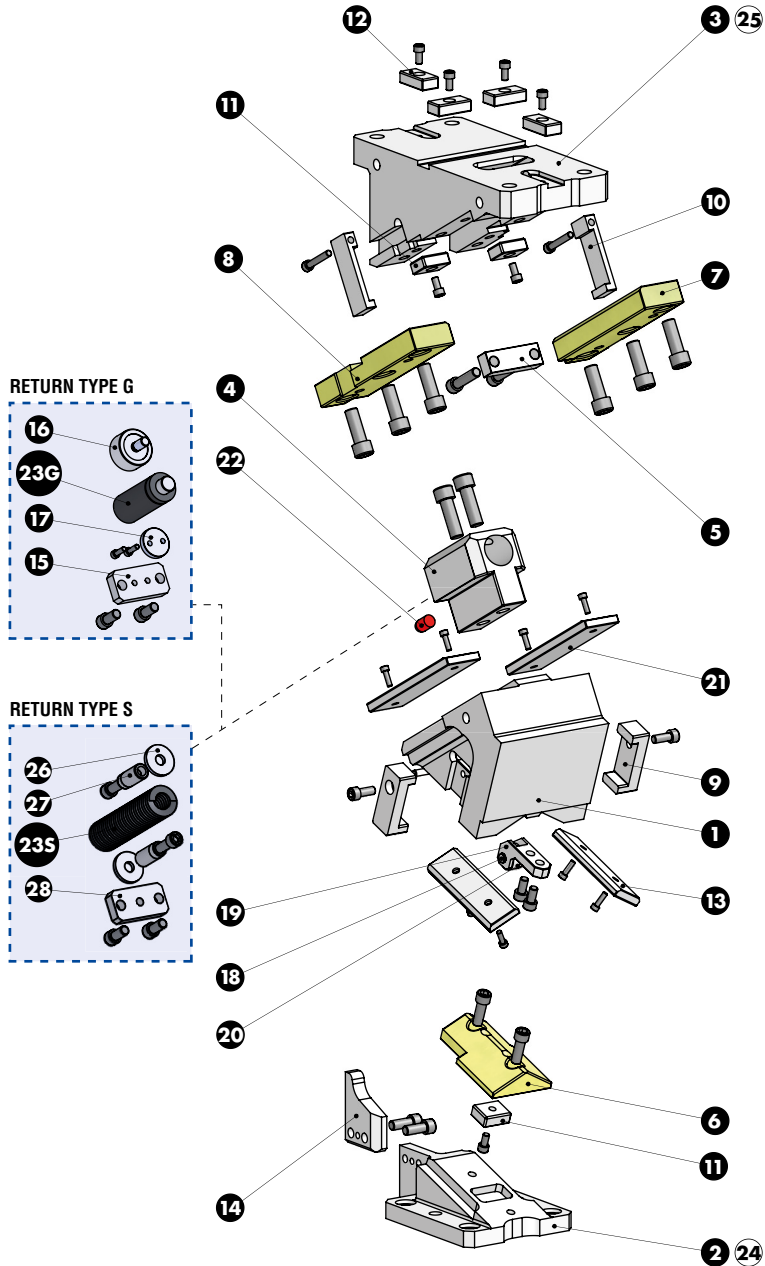

AERIAL CAM UNIT - OBEN HÄNGENDER SCHIEBER - UNITÀ A CAMME SOSPESA

SLIDER STRUCTURE, POSITIVE RETURN STRUCTURE AND CLEARANCES

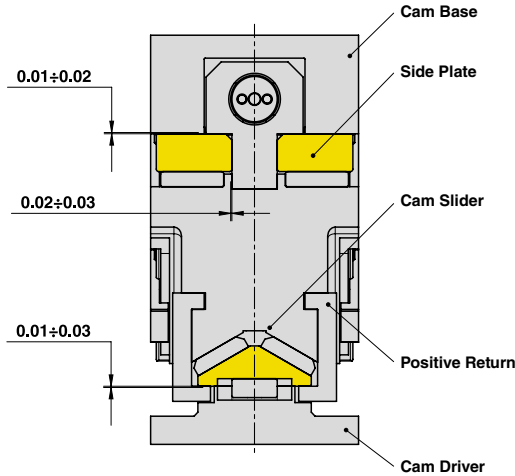

PART LIST

Particular number	Description	Material	Quantity
1	Cam Slider	GG-25	1
2	Cam Driver	GG-25	1
3	Cam Base	GG-25	1
4	Spring Guide Block	CK45 + Graphite	1
5	Stopper Plate	CK45	1
6	Male "V" Driver	CuZn25Al5 + Graphite - HB > 190	1
7	Side Plate R	CuZn25Al5 + Graphite - HB > 190	1
8	Side Plate L	CuZn25Al5 + Graphite - HB > 190	1
9	Positive Return	42CrMo4 Nitrided	2
10	Positive Return	CK45	2
11	Key	CK45	3
12	Key	CK45	4
13	Wear Plate	CK45	2
14	Accelerator	CK45	1
15	Spring Stopper Plate	CK45	1
16	Spring Guide Pin	CK45	1
17	Spring Spacer	CK45	1
18	Shaft	CK45	1
19	Roller Bracket	CK45	1
20	Roller	NATR15PP	1
21	Wear Plate VDI 3357	CK45	2
22	Elastomer Cap	Elastomer 92SH	1
23G	Gas Spring - Return Type G	-	1
23S	Spring - Return Type S	-	1
24	Cam Driver Fixing Screws M16x50 DIN 912	-	4
25	Cam Base Fixing Screws M16x60 DIN 912	-	4
26	Washer	CK45	1
27	Spring Guide Pin	CK45	1
28	Spring Stopper Plate	CK45	1

AERIAL CAM UNIT - OBEN HÄNGENDER SCHIEBER - UNITÀ A CAMME SOSPESA

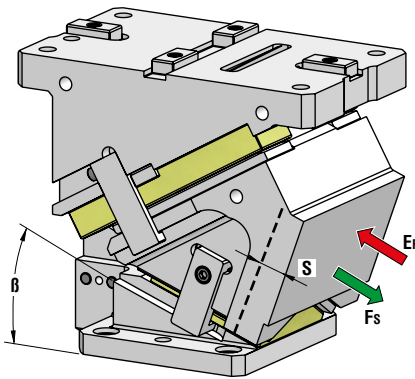

OMCR CODE	Work Angle	Stroke (mm)	Max Work Force with shoulder (kN)	Extraction Force (kN)	
	β			S	Fs
				Spring	Gas Spring
CHR200.00	0°	32,14	408	2,35	4,82
CHR200.05	5°	35,49	408	2,35	4,82
CHR200.10	10°	38,89	408	2,35	4,82
CHR200.15	15°	42,40	408	2,35	4,82
CHR200.20	20°	46,08	408	2,35	4,82
CHR200.25	25°	50	408	2,35	4,82
CHR200.30	30°	54,25	408	2,35	4,82
CHR200.35	35°	58,96	408	2,35	4,82
CHR200.40	40°	64,28	408	2,35	4,82
CHR200.45	45°	70,44	408	2,35	4,82
CHR200.50	50°	77,79	408	2,35	4,82
CHR200.55	55°	87,17	408	2,09	4,30
CHR200.60	60°	100	408	1,82	3,75

OPTION CODE

N

Dowel pin hole $\varnothing 16$ H7 drilled on Cam Base

*Return Type: G = Gas Spring / S = Spring



				OPTION CODE
Art.	Work Angle = 5°	Return Type*		N
CHR200	05	G		N16

OMCR CODE	Work Angle	Overall Dimensions (mm)					
	β	A	B	C	D	E	F
CHR200.00	0°	335,84	96,98	128	318	154,84	55
CHR200.05	5°	335,25	100,91	113	303	155,32	55
CHR200.10	10°	337,27	111,09	101	291	159,30	50
CHR200.15	15°	329,78	122,46	80	270	156,45	45
CHR200.20	20°	332,68	129,99	70	260	162,11	42
CHR200.25	25°	332,88	138,62	58	248	167,33	37
CHR200.30	30°	334,28	148,28	48	238	170,39	30
CHR200.35	35°	329,80	158,89	33	223	167,66	25
CHR200.40	40°	321,35	170,38	15	205	161,18	25
CHR200.45	45°	314,86	182,66	0	190	155,49	25
CHR200.50	50°	307,27	195,63	-15	175	149,10	0
CHR200.55	55°	296,59	210,30	-32	158	121,17	0
CHR200.60	60°	288,56	222,26	-45	145	113,04	0

AERIAL CAM UNIT - OBEN HÄNGENDER SCHIEBER - UNITÀ A CAMME SOSPESA

X VIEW

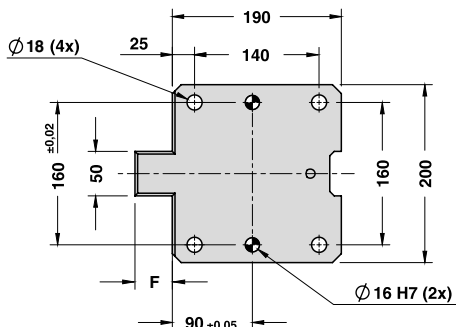
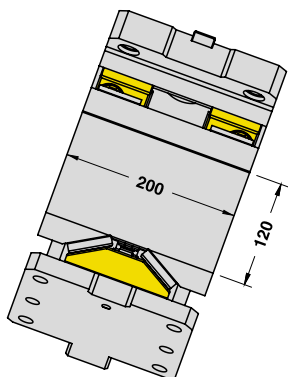

CAM DIAGRAM

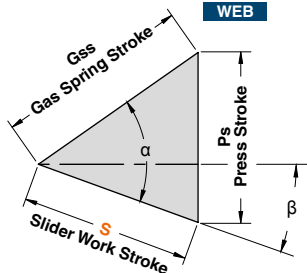

Accelerator available for work angles from 0° to 25°

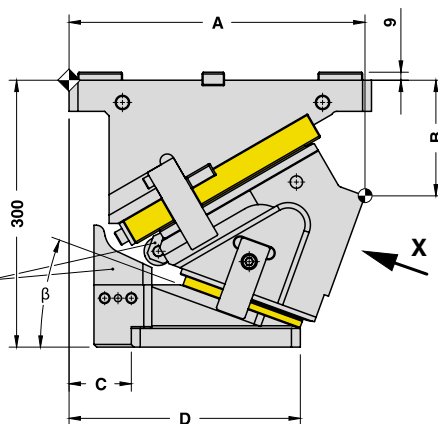

Work Angle	Inner Angle	Slider Work Stroke (mm)	Press Stroke (mm)	Gas Spring Stroke (mm)
β	α	S	Ps	Gss
0°	50°	32,14	38,30	50
5°	50°	35,49	38,45	50
10°	50°	38,89	38,89	50
15°	50°	42,40	39,65	50
20°	50°	46,08	40,76	50
25°	50°	50,00	42,26	50
30°	50°	54,25	44,23	50
35°	50°	58,96	46,76	50
40°	50°	64,28	50,00	50
45°	50°	70,44	54,17	50
50°	50°	77,79	59,59	50
55°	55°	87,17	71,41	50
60°	60°	100,00	86,60	50

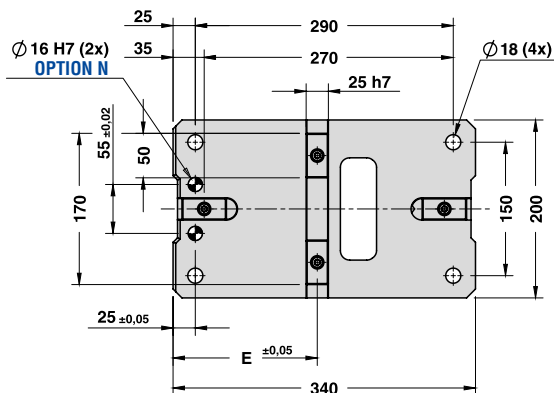

RETURN TYPE G

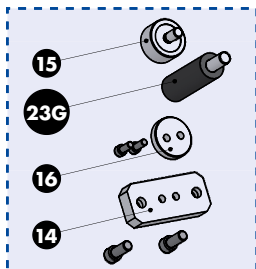

RETURN TYPE S

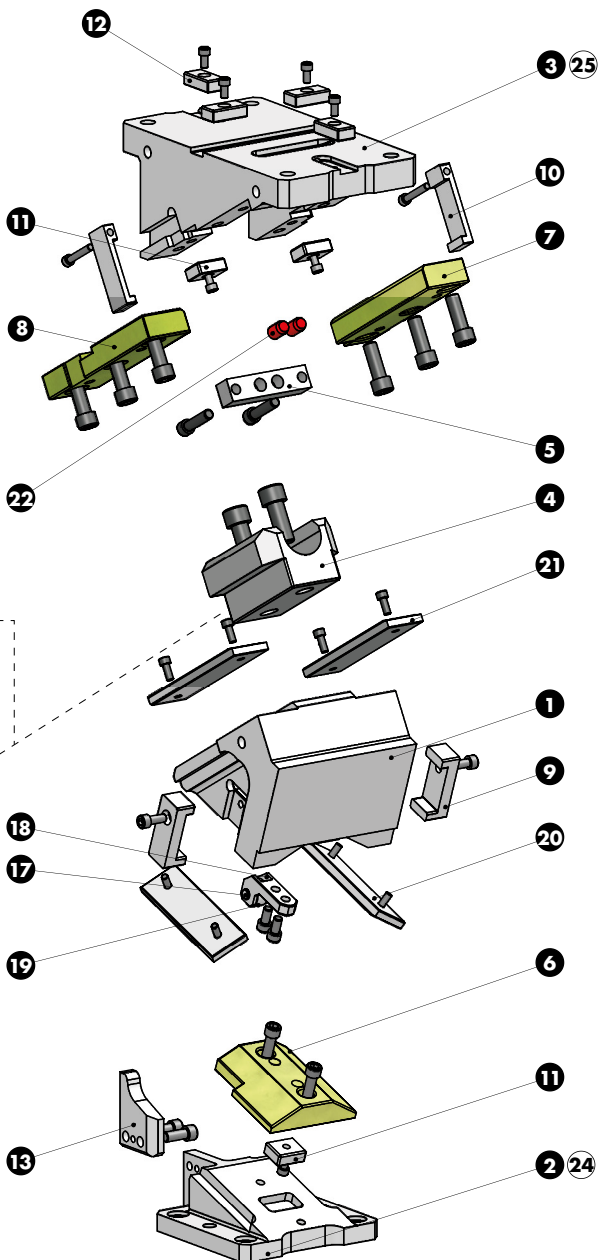
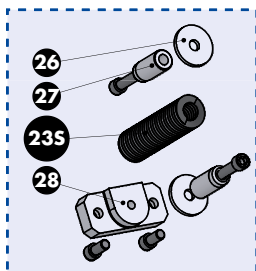

AERIAL CAM UNIT - OBEN HÄNGENDER SCHIEBER - UNITÀ A CAMME SOSPESA

SLIDER STRUCTURE, POSITIVE RETURN STRUCTURE AND CLEARANCES

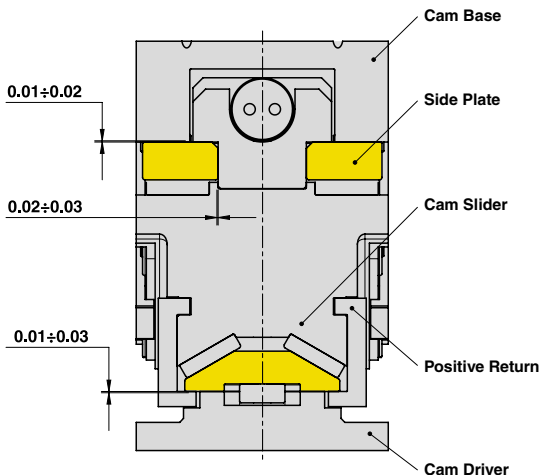

PART LIST

Particular number	Description	Material	Quantity
1	Cam Slider	GG-25	1
2	Cam Driver	GG-25	1
3	Cam Base	GG-25	1
4	Spring Guide Block	CK45 + Graphite	1
5	Stopper Plate	CK45	1
6	Male "V" Driver	CuZn25Al5 + Graphite - HB > 190	1
7	Side Plate R	CuZn25Al5 + Graphite - HB > 190	1
8	Side Plate L	CuZn25Al5 + Graphite - HB > 190	1
9	Positive Return	42CrMo4 Nitrided	2
10	Positive Return	CK45	2
11	Key	CK45	3
12	Key	CK45	4
13	Accelerator	CK45	1
14	Spring Stopper Plate	CK45	1
15	Spring Guide Pin	CK45	1
16	Gas Spring Spacer	CK45	1
17	Shaft	CK45	1
18	Roller Bracket	CK45	1
19	Roller	NATR15PP	1
20	Wear Plate VDI 3357	CK45	2
21	Wear Plate VDI 3357	CK45	2
22	Elastomer Cap	Elastomer 92SH	2
23G	Gas Spring - Return Type G	-	1
23S	Spring - Return Type S	-	1
24	Cam Driver Fixing Screws M16x50 DIN 912	-	4
25	Cam Base Fixing Screws M16x60 DIN 912	-	4
26	Washer	CK45	1
27	Spring Guide Pin	CK45	1
28	Spring Stopper Plate	CK45	1

AERIAL CAM UNIT - OBEN HÄNGENDER SCHIEBER - UNITÀ A CAMME SOSPESA

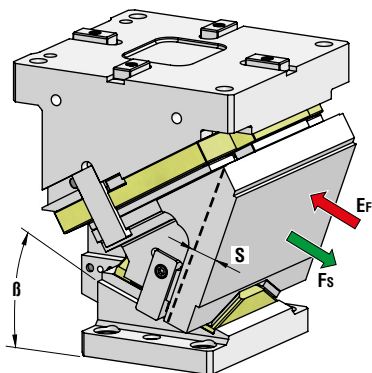

OMCR CODE	Work Angle	Stroke (mm)	Max Work Force with shoulder (kN)	Extraction Force (kN)	
	β	S	F _s	Spring	Gas Spring
CHR300.00	0°	38,57	521	5,09	9,40
CHR300.05	5°	42,59	521	5,09	9,40
CHR300.10	10°	46,67	521	5,09	9,40
CHR300.15	15°	50,88	521	5,09	9,40
CHR300.20	20°	55,30	521	5,09	9,40
CHR300.25	25°	60	521	5,09	9,40
CHR300.30	30°	65,10	521	5,09	9,40
CHR300.35	35°	70,75	521	5,09	9,40
CHR300.40	40°	77,13	521	5,09	9,40
CHR300.45	45°	84,53	521	5,09	9,40
CHR300.50	50°	79,34	521	4,36	8,80
CHR300.55	55°	88,92	521	3,89	7,85
CHR300.60	60°	102	521	3,39	6,85

OPTION CODE

N Dowel pin hole Ø16 H7 drilled on Cam Base

*Return Type: G = Gas Spring / S = Spring



Art.	Work Angle = 5°	Return Type*	OPTION CODE
CHR300	05	G	N N16

OMCR CODE	Work Angle	Overall Dimensions (mm)					
	β	A	B	C	D	E	F
CHR300.00	0°	313	98	138	328	119,50	55
CHR300.05	5°	317,15	104,18	125	315	127,13	55
CHR300.10	10°	324,13	111,86	115	305	138,04	55
CHR300.15	15°	325,82	121,01	100	290	144,41	55
CHR300.20	20°	327,08	131,59	85	275	151,45	55
CHR300.25	25°	334,71	138,65	75	265	164,01	50
CHR300.30	30°	327,83	146,89	55	245	159,87	45
CHR300.35	35°	334,51	159,17	45	235	169,57	35
CHR300.40	40°	325,46	167,30	25	215	159,82	30
CHR300.45	45°	324,84	179,23	7	197	160,54	30
CHR300.50	50°	306,63	196,84	-35	155	137,58	0
CHR300.55	55°	277,93	229,29	-85	105	120,29	0
CHR300.60	60°	286,45	245,64	-85	105	124,79	0

AERIAL CAM UNIT - OBEN HÄNGENDER SCHIEBER - UNITÀ A CAMME SOSPESA

X VIEW

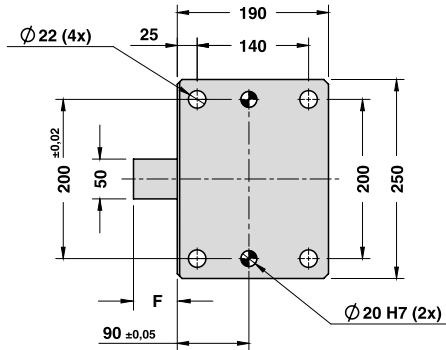
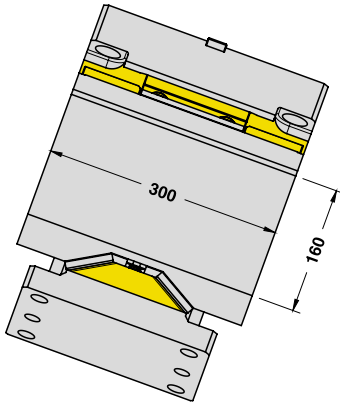

CAM DIAGRAM

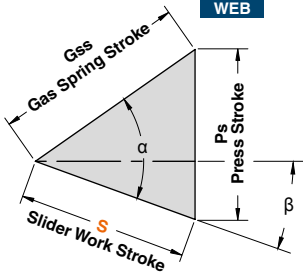

Accelerator available for work angles from 0° to 25°

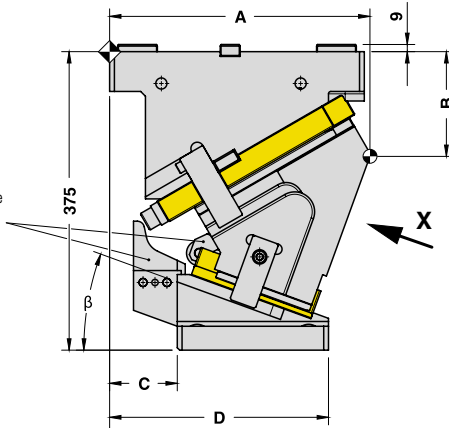

Work Angle	Inner Angle	Slider Work Stroke (mm)	Press Stroke (mm)	Gas Spring Stroke (mm)
β	α	S	Ps	Gss
0°	50°	38,57	45,96	60
5°	50°	42,59	46,14	60
10°	50°	46,67	46,67	60
15°	50°	50,88	47,58	60
20°	50°	55,30	48,91	60
25°	50°	60,00	50,71	60
30°	50°	65,10	53,07	60
35°	50°	70,75	56,11	60
40°	50°	77,13	60,00	60
45°	50°	84,53	65,00	60
50°	50°	79,34	60,78	51
55°	55°	88,92	72,84	51
60°	60°	102,00	88,33	51

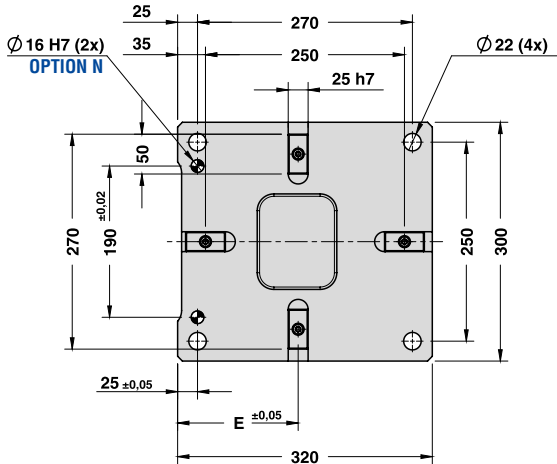

AERIAL CAM UNIT - OBEN HÄNGENDER SCHIEBER - UNITÀ A CAMME SOSPESA

RETURN TYPE G

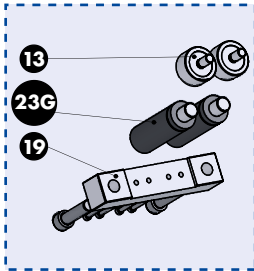

RETURN TYPE S

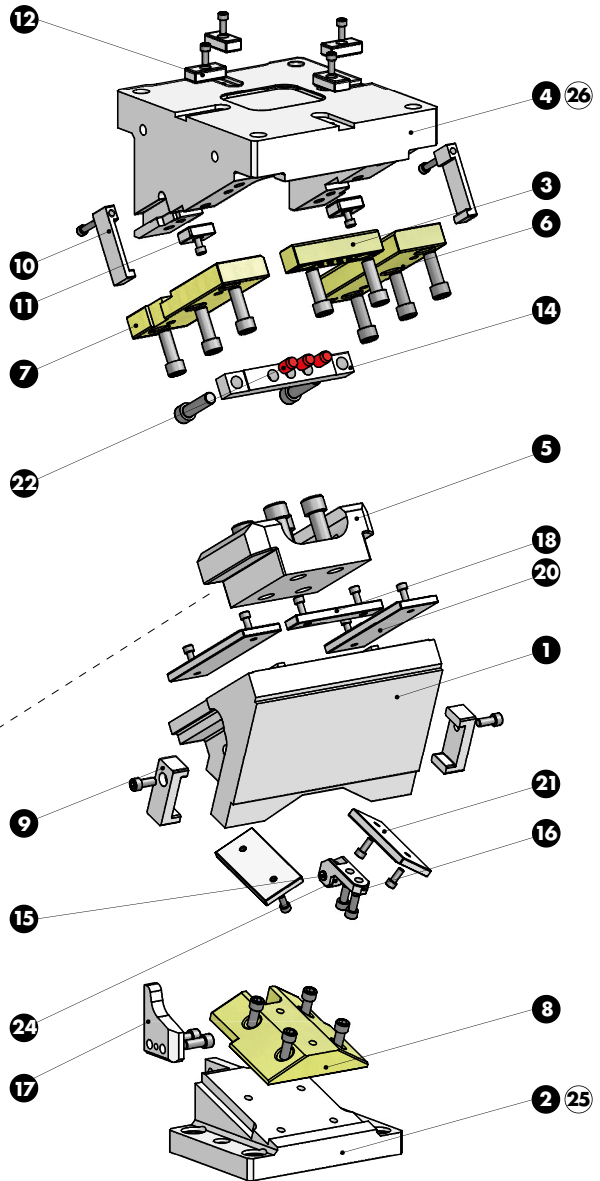
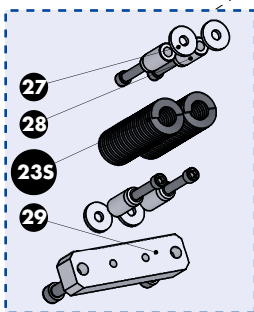

AERIAL CAM UNIT - OBEN HÄNGENDER SCHIEBER - UNITÀ A CAMME SOSPESA

SLIDER STRUCTURE, POSITIVE RETURN STRUCTURE AND CLEARANCES

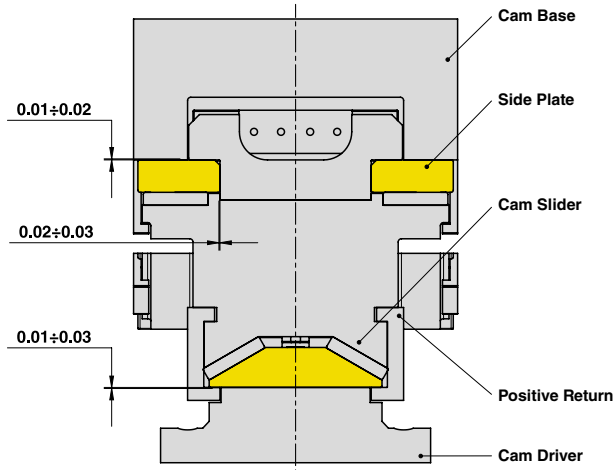

PART LIST

Particular number	Description	Material	Quantity
1	Cam Slider	GG-25	1
2	Cam Driver	GG-25	1
3	Plate	CuZn25Al5 + Graphite - HB > 190	1
4	Cam Base	GG-25	1
5	Spring Guide Block	CK45 + Graphite	1
6	Side Plate R	CuZn25Al5 + Graphite - HB > 190	1
7	Side Plate L	CuZn25Al5 + Graphite - HB > 190	1
8	Male "V" Driver	CuZn25Al5 + Graphite - HB > 190	1
9	Positive Return	42CrMo4 Nitrided	2
10	Positive Return	CK45	2
11	Key	CK45	2
12	Key	CK45	4
13	Spring Guide Pin	CK45	2
14	Stopper Plate	CK45	1
15	Shaft	CK45	1
16	Roller Bracket	CK45	1
17	Accelerator	CK45	1
18	Plate	CK45	1
19	Spring Stopper Plate	CK45	1
20	Wear Plate VDI 3357	CK45	2
21	Wear Plate VDI 3357	CK45	2
22	Elastomer Cap	Elastomer 92SH	3
23G	Gas Spring - Return Type G	-	2
23S	Spring - Return Type S	-	2
24	Roller	NATR15PP	1
25	Cam Driver Fixing Screws M20x65 DIN 912	-	4
26	Cam Base Fixing Screws M20x75 DIN 912	-	4
27	Washer	CK45	2
28	Spring Guide Pin	CK45	2
29	Spring Stopper Plate	CK45	1

AERIAL CAM UNIT - OBEN HÄNGENDER SCHIEBER - UNITÀ A CAMME SOSPESA

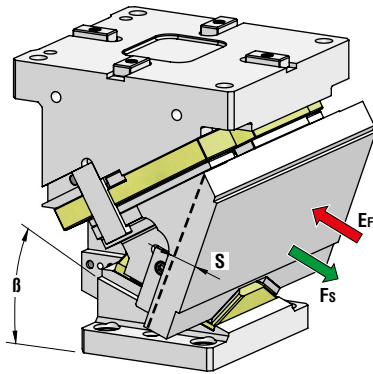

OMCR CODE	Work Angle	Stroke (mm)	Max Work Force with shoulder (kN)	Extraction Force (kN)	
	β	S	F_s	Spring	Gas Spring
CHR400.00	0°	38,57	521	5,09	9,40
CHR400.05	5°	42,59	521	5,09	9,40
CHR400.10	10°	46,67	521	5,09	9,40
CHR400.15	15°	50,88	521	5,09	9,40
CHR400.20	20°	55,30	521	5,09	9,40
CHR400.25	25°	60	521	5,09	9,40
CHR400.30	30°	65,10	521	5,09	9,40
CHR400.35	35°	70,75	521	5,09	9,40
CHR400.40	40°	77,13	521	5,09	9,40
CHR400.45	45°	84,53	521	5,09	9,40
CHR400.50	50°	79,34	521	4,36	8,80
CHR400.55	55°	88,92	521	3,89	7,85
CHR400.60	60°	102	521	3,39	6,85

OPTION CODE

N

Dowel pin hole $\varnothing 16$ H7 drilled on Cam Base

*Return Type: G = Gas Spring / S = Spring



Art.	Work Angle = 5°	Return Type*	OPTION CODE
CHR400	05	G	N N16

OMCR CODE	Work Angle	Overall Dimensions (mm)					
	β	A	B	C	D	E	F
CHR400.00	0°	313	98	138	328	119,50	55
CHR400.05	5°	317,15	104,18	125	315	127,13	55
CHR400.10	10°	324,13	111,86	115	305	138,04	55
CHR400.15	15°	325,82	121,01	100	290	144,41	55
CHR400.20	20°	327,08	131,59	85	275	151,45	55
CHR400.25	25°	334,71	138,65	75	265	164,01	50
CHR400.30	30°	327,83	146,89	55	245	159,87	45
CHR400.35	35°	334,51	159,17	45	235	169,57	35
CHR400.40	40°	325,46	167,30	25	215	159,82	30
CHR400.45	45°	324,84	179,23	7	197	160,54	30
CHR400.50	50°	306,63	196,84	-35	155	137,58	0
CHR400.55	55°	277,93	229,29	-85	105	120,29	0
CHR400.60	60°	286,45	245,64	-85	105	124,79	0

AERIAL CAM UNIT - OBEN HÄNGENDER SCHIEBER - UNITÀ A CAMME SOSPESA

X VIEW

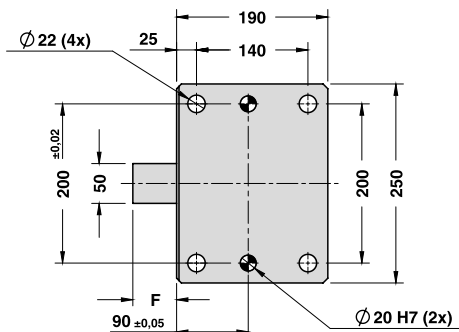
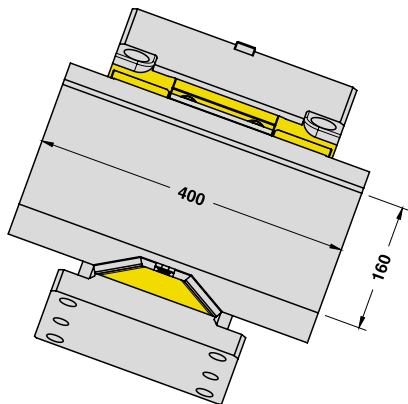

CAM DIAGRAM

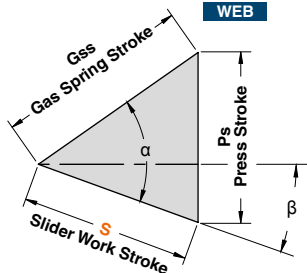

Accelerator available for work angles from 0° to 25°

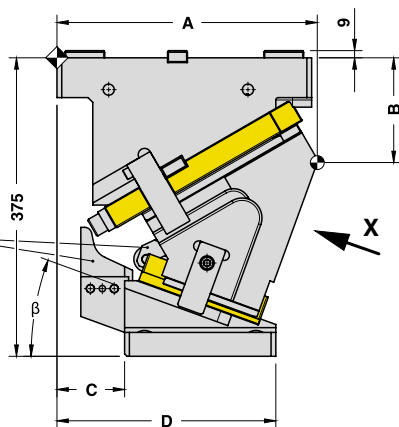

Work Angle	Inner Angle	Slider Work Stroke (mm)	Press Stroke (mm)	Gas Spring Stroke (mm)
β	α	S	Ps	Gss
0°	50°	38,57	45,96	60
5°	50°	42,59	46,14	60
10°	50°	46,67	46,67	60
15°	50°	50,88	47,58	60
20°	50°	55,30	48,91	60
25°	50°	60,00	50,71	60
30°	50°	65,10	53,07	60
35°	50°	70,75	56,11	60
40°	50°	77,13	60,00	60
45°	50°	84,53	65,00	60
50°	50°	79,34	60,78	51
55°	55°	88,92	72,84	51
60°	60°	102,00	88,33	51

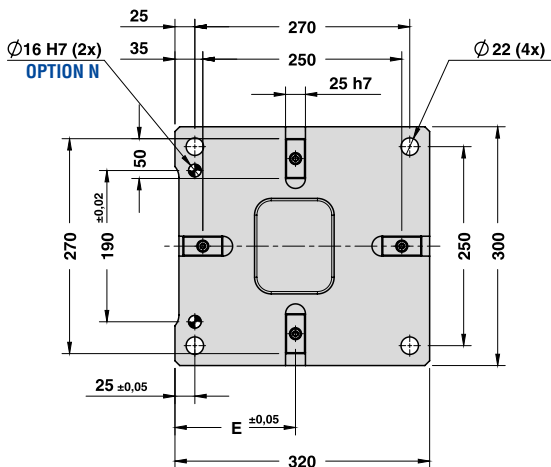

Cam Units CHR

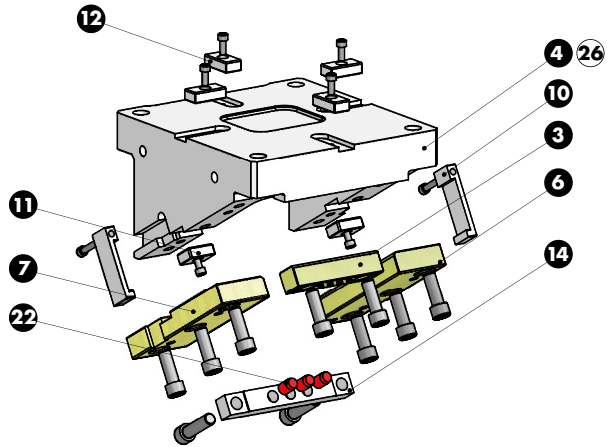

RETURN TYPE G

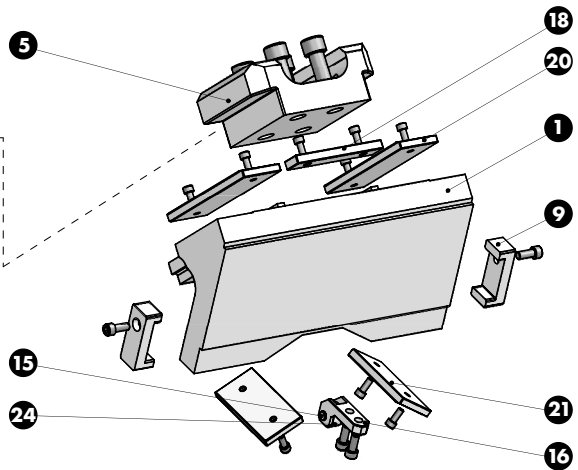
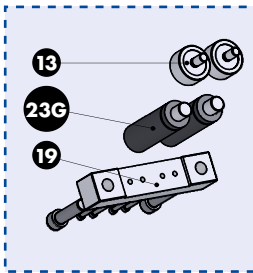

RETURN TYPE S

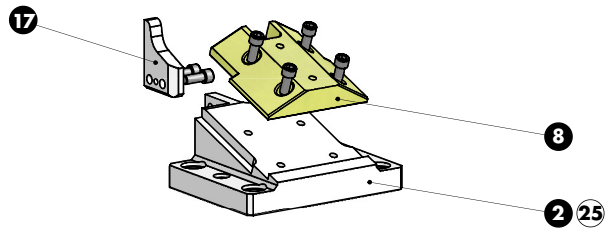
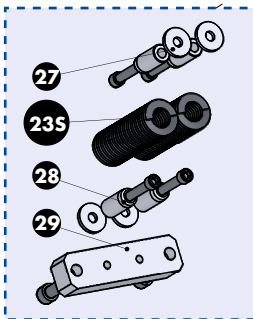

AERIAL CAM UNIT - OBEN HÄNGENDER SCHIEBER - UNITÀ A CAMME SOSPESA

SLIDER STRUCTURE, POSITIVE RETURN STRUCTURE AND CLEARANCES

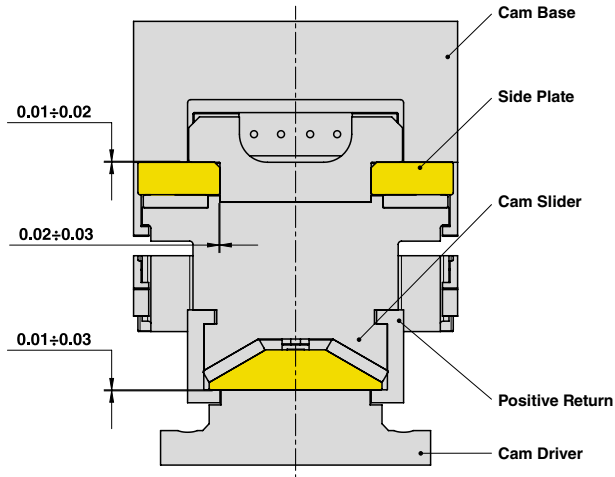

PART LIST

Particular number	Description	Material	Quantity
1	Cam Slider	GG-25	1
2	Cam Driver	GG-25	1
3	Plate	CuZn25Al5 + Graphite - HB > 190	1
4	Cam Base	GG-25	1
5	Spring Guide Block	CK45 + Graphite	1
6	Side Plate R	CuZn25Al5 + Graphite - HB > 190	1
7	Side Plate L	CuZn25Al5 + Graphite - HB > 190	1
8	Male "V" Driver	CuZn25Al5 + Graphite - HB > 190	1
9	Positive Return	42CrMo4 Nitrided	2
10	Positive Return	CK45	2
11	Key	CK45	2
12	Key	CK45	4
13	Spring Guide Pin	CK45	2
14	Stopper Plate	CK45	1
15	Shaft	CK45	1
16	Roller Bracket	CK45	1
17	Accelerator	CK45	1
18	Plate	CK45	1
19	Spring Stopper Plate	CK45	1
20	Wear Plate VDI 3357	CK45	2
21	Wear Plate VDI 3357	CK45	2
22	Elastomer Cap	Elastomer 92SH	3
23G	Gas Spring - Return Type G	-	2
23S	Spring - Return Type S	-	2
24	Roller	NATR15PP	1
25	Cam Driver Fixing Screws M20x65 DIN 912	-	4
26	Cam Base Fixing Screws M20x75 DIN 912	-	4
27	Washer	CK45	2
28	Spring Guide Pin	CK45	2
29	Spring Stopper Plate	CK45	1